

Multispectral snapshot microscopy as an exposure assessment tool

Carolina Blanch-Perez-del-Notario^a, Amir Asadollahi^a, Pieter Bertier^b, Murali Jayapala^a

^aimec, Belgium; ^bBelgian Center for Occupational Hygiene

WHISPERS, Helsinki, 10th December 2024



Context of EXIMIOUS

MAPPING EXPOSURE-INDUCED IMMUNE DISEASES

- Exposure samples
 - Silica (skin & inhalation) + toxicity of silica
 - Metals and metalloids (skin & inhalation)
 - Organic compounds
 - Organic dusts - microplastics and natural polymers
 - Volatile organic substances (skin & inhalation)
- Current techniques for exposure assessment:
 - Sampling: active sampling (e.g. filters), diffusive sampling ..
 - Analysis: X-Ray Diffraction Analysis (XRD), Fourier Transform Infra-red (FTIR), Scanning Electron Microscopy (SEM), Phase Contrast Microscopy.....
 - Expensive equipment, time-consuming, offsite postprocessing
 - **Can hyperspectral imaging be a cost-efficient alternative for fast on-site exposure assessment?**

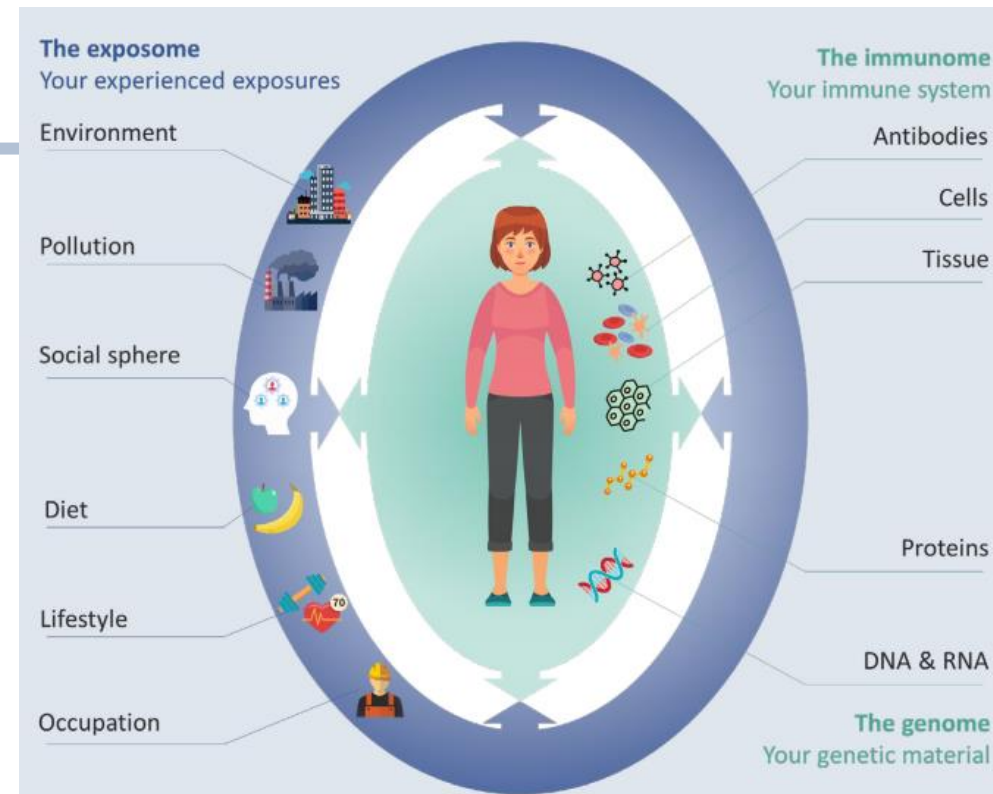

Imec integrated approach

ON-CHIP SPECTRAL IMAGING

Traditional spectral system

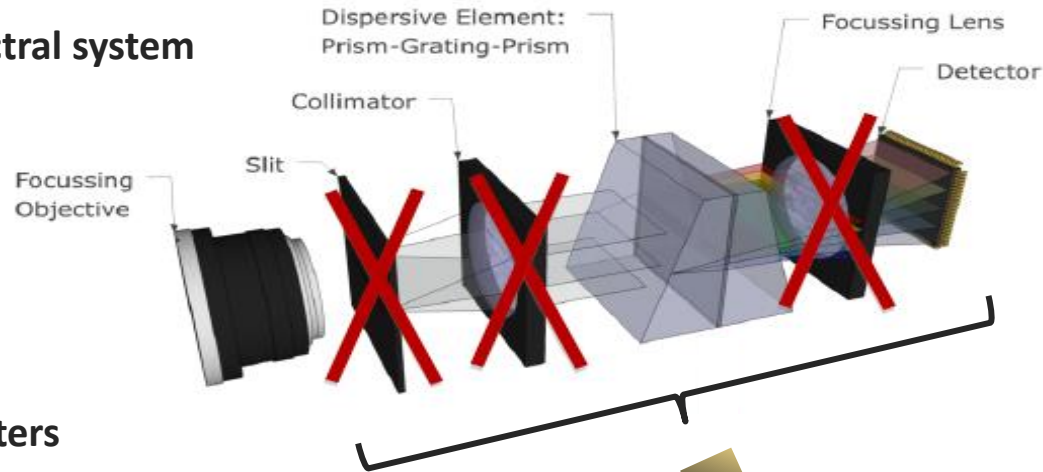

imec on-chip filters

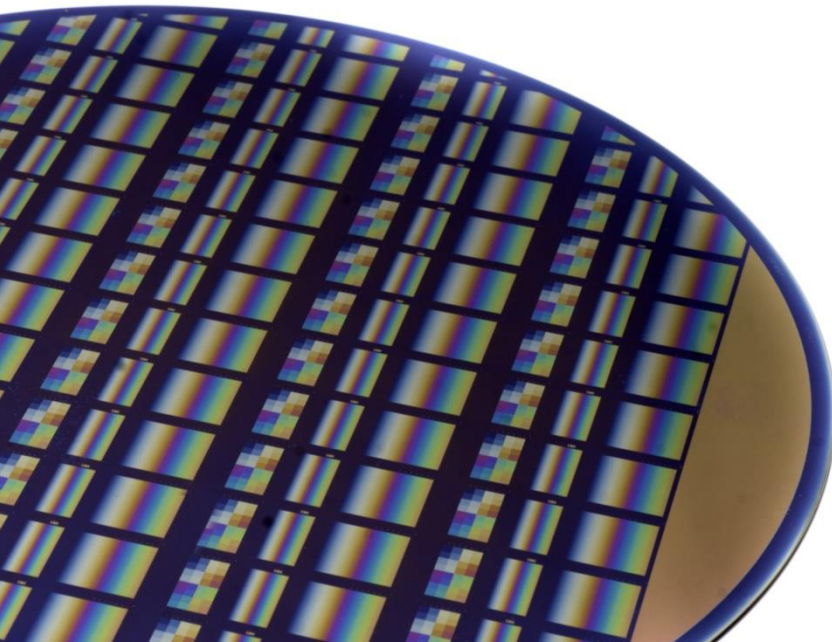

On-chip spectral filters

- Scalable CMOS process
- Snapshot, video & scanning
- Miniaturized and robust
- Easy to integrate @ application level
- VIS, NIR, SWIR and beyond



Higher resolution versus lower resolution systems



Snapscan systems

INTERNAL SCANNING

Highest spatial & spectral resolution
150 spectral band images in 460-900nm range
up to 7MPx spatial resolution
~ 1min/image acquisition speed

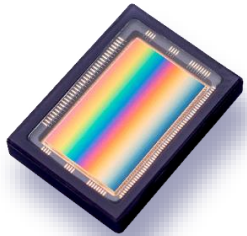

Snapshot systems

NO SCAN = real-time HSI acquisition

Spatial vs. Spectral resolution trade-off
VIS: 16 band images of 512x272 pixels (460-600 nm)
NIR: 16 band images of 512x272 pixels (600-850 nm)
NIR: 25 band images of 409x216 pixels (660-950 nm)
Video acquisition (170 images/second)

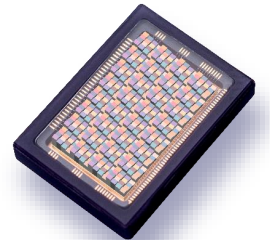

HSI potential for fast and cost-efficient particle inspection

Potential for quick assessment of contaminant exposure



Evaluation of optimal substrate/sampling method

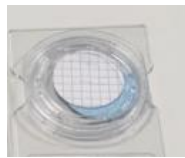
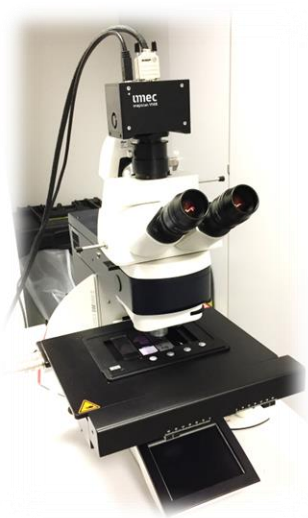

Traditional sampling methods versus practical approach



Potential for miniaturization/integration of HSI sensor with portable microscope

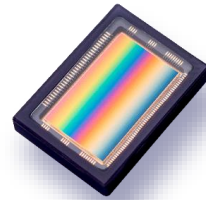

System on chip without bulky optical components



Courtesy of Grundium

Potential spectral discrimination

Spectral library of materials

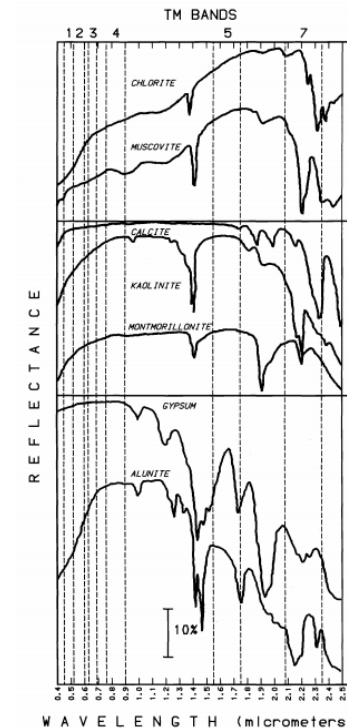

Classified image of particles

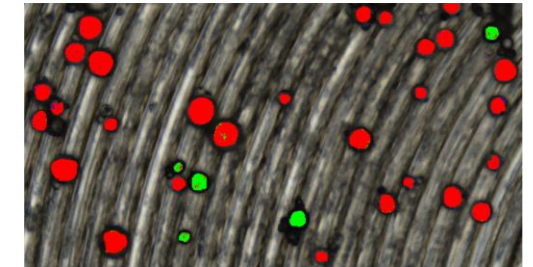

Classification Method

(Machine learning)



Sampling method for exposure assessment

Practical sampling approach to sample particles at worksite

Glass slide + tape pressed onto surface (e.g shelf)

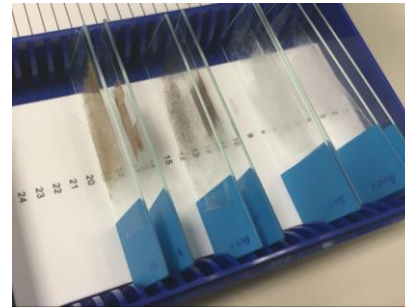

HSI camera on Transmission microscope



Mimic 15 sample materials (type and size distribution) from worksite

Parameter	Calcite	Carbon	Dolomite	Gibbsite	Gypsum	Hematite	Kaolinite	Barite
Mean (µm)	4.80	6.36	3.44	6.72	3.80	3.99	4.82	6.49
StandardDev	4.34	5.18	2.66	4.83	2.25	2.93	3.34	5.99
Parameter	Feldspar	Muscovite	Phlogopite	Quartz	Rutile	Smectite	K-spar	
Mean (µm)	5.03	0.42	3.39	3.78	0.31	1.59	5.01	
StandardDev	3.53	0.30	2.32	2.12	0.54	1.06	3.19	

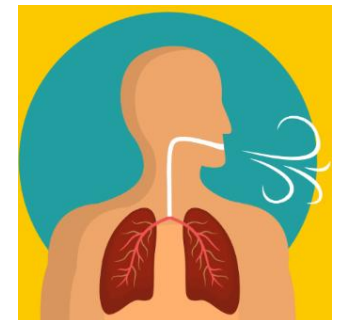

Respirable particles (< 15µm)

High resolution (non-portable) system

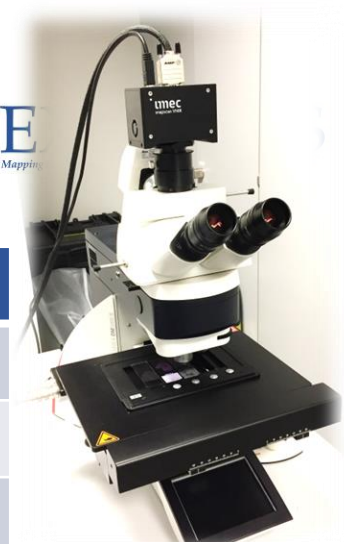

Mean transmittance spectra

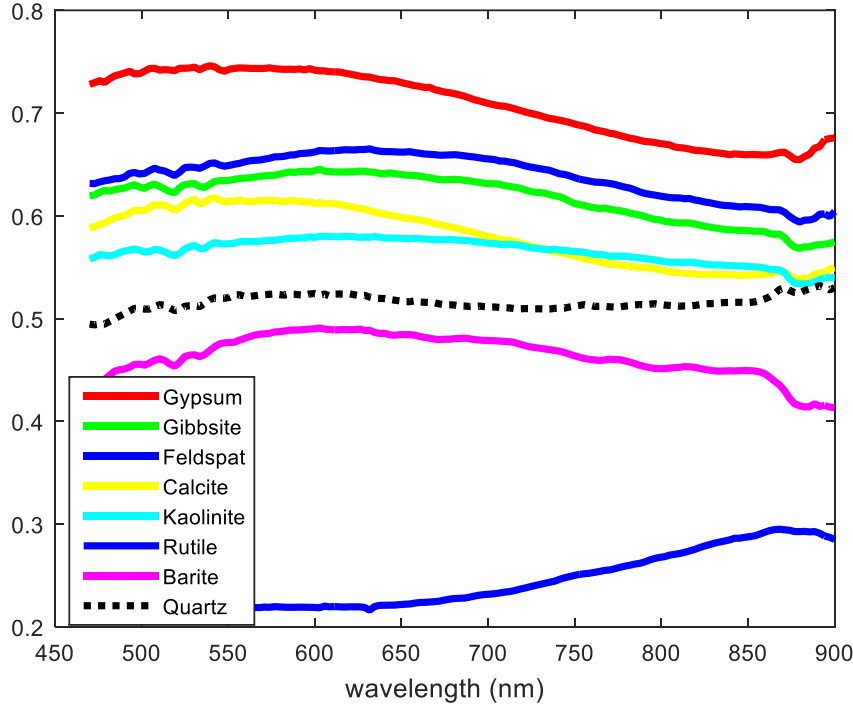

Pixel classification accuracy

Classifier	Mean Acc	Max Acc	Min Acc
LDA + QDC	69.38%	97%	12% (5<50%)
Random Forest (RF)	93%	100%	83%
LDA + RF	90.5%	99%	78%

- Hematite
- Gypsum
- Muscovite
- Gibbsite
- Dolomite
- Feldspar
- Phlogopite
- Calcite
- Smectite
- Kaolinite
- K-Spar
- Rutile
- Coal
- Barite
- Quartz

Hematite

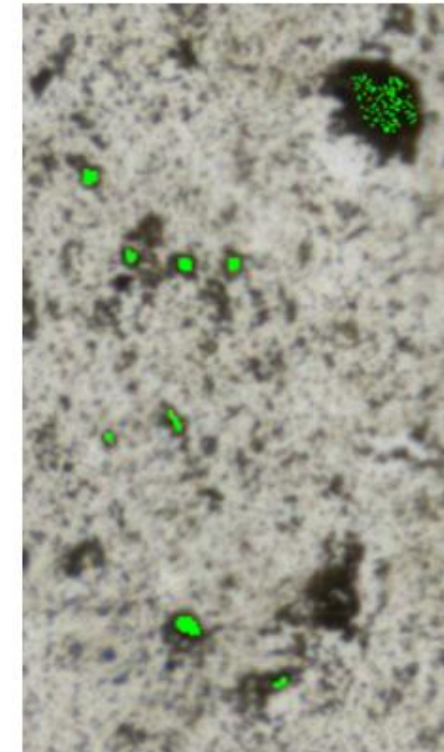

Muscovite

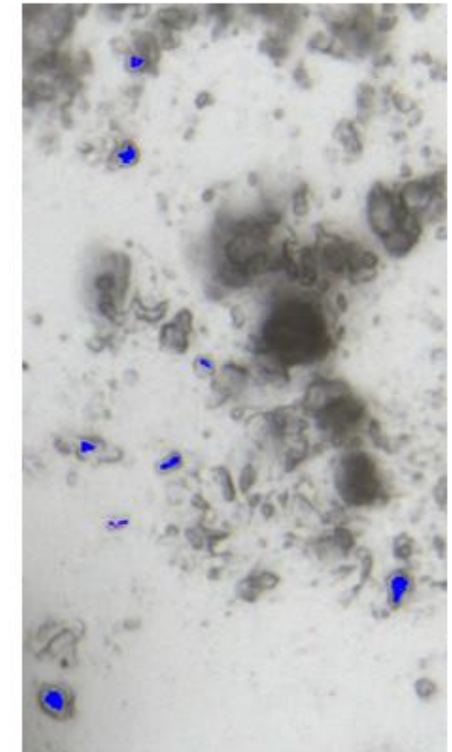

Band relevance analysis

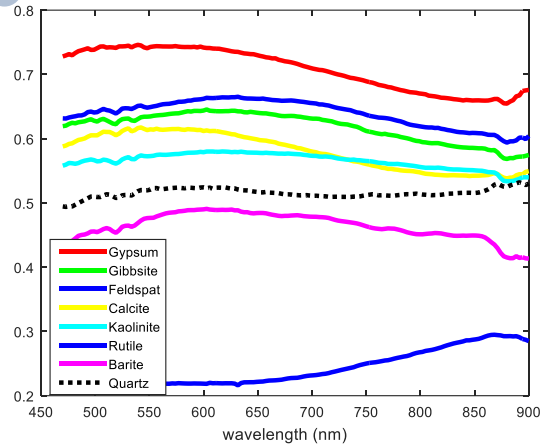

Genetic Algorithm

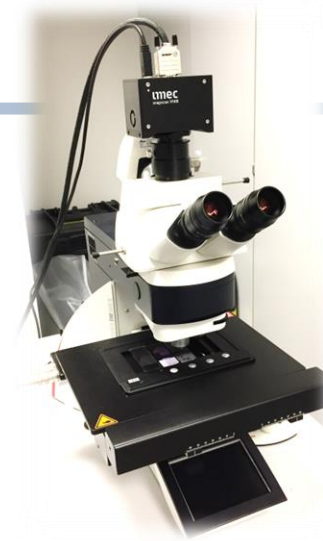

Few spectral bands are needed → fast lower resolution cameras can be used

Range	Mean	Max	Min
Snapscan VNIR 150 bands 460-900 nm	92.9%	99%	83%
Best 9 bands (470-472.8-513-726.8 -816.3-850.9-874-879.8)	90.7%	99%	77%
Best 5 bands (484.4-562.2-640.2-850.9-885.5)	90.5%	99%	75%
Best 3 bands (643.1-718.1-871.1)	90.3%	99%	71%
Snapshot NIR 25 bands (675-950 nm)	90.2%	99%	76%
Snapshot NIR 16 bands (600-850 nm)	90.1%	99%	81% (quartz)

Mean Pixel Classification accuracy (%) for different particle materials



High accuracy for snapshot NIR cameras in microscopy

Confusion matrix for NIR5x5 data on 14 particle materials, QDC, MF5x5

Mean transmittance spectra

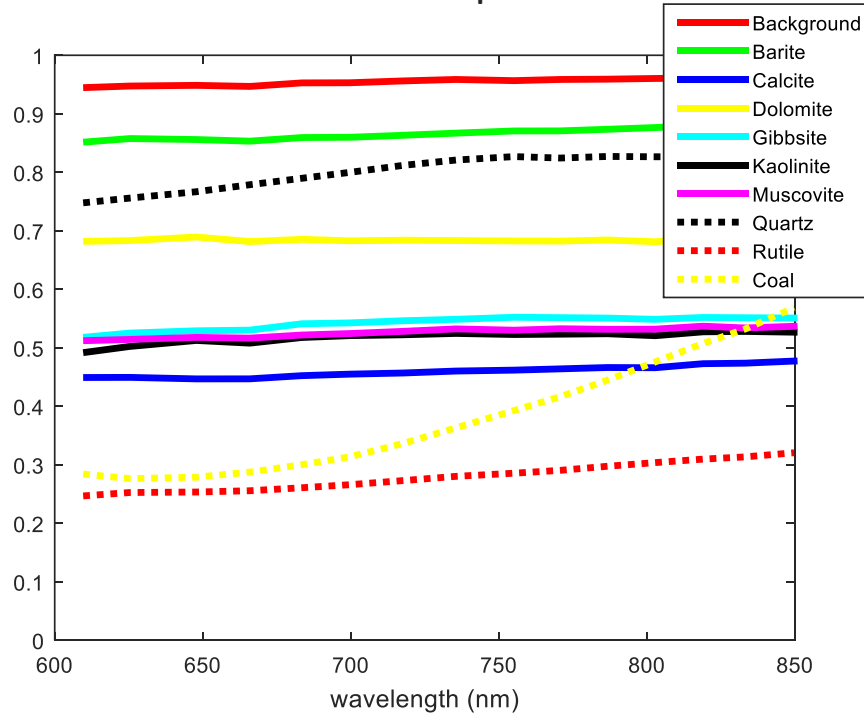

RedNIR 4x4
(600-850 nm)



20X magnification

Decisions

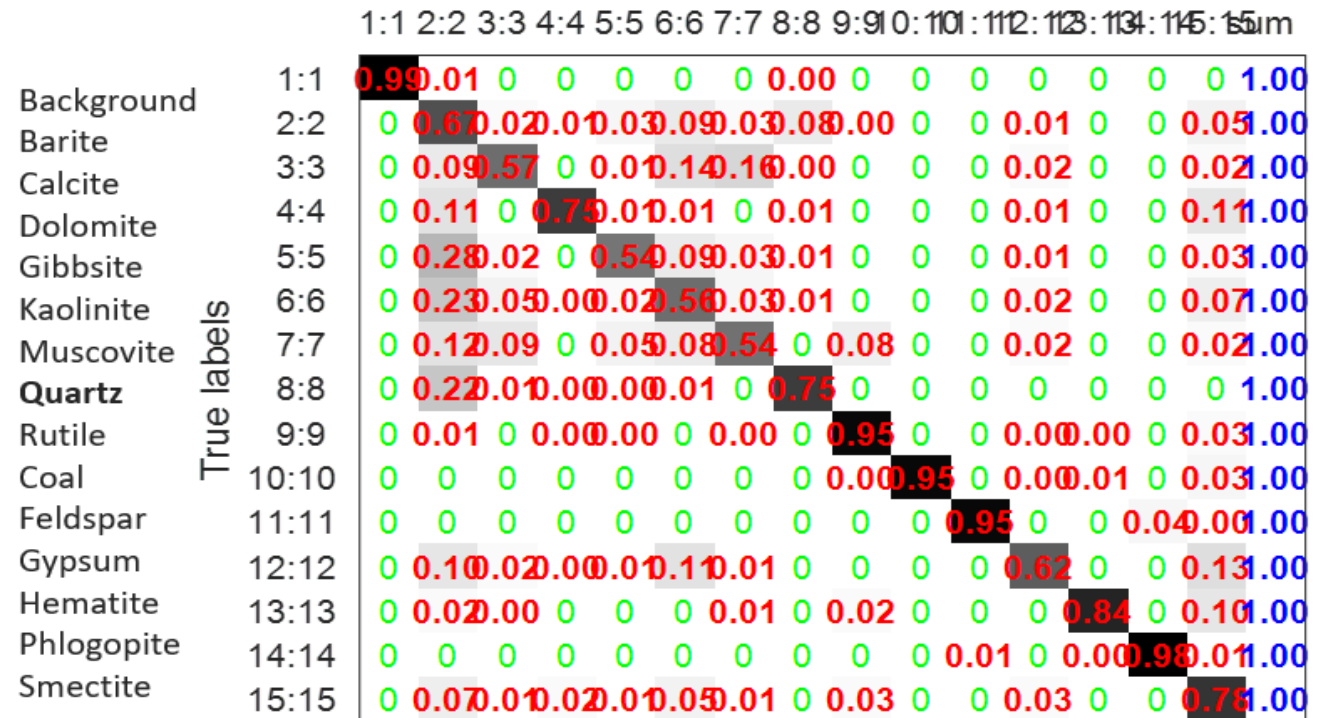

High accuracy for snapshot NIR cameras in microscopy

Pixel classification accuracy (mf5x5 as preprocessing)

Camera	Classif	Mean/Min(all)	Mean/Min (8 target)
RedNIR 600-860nm	QDC	58.9%/13.6%	74.7% /23.3%
	RF	67.0%/30.4%	81.7% /45.7%
NIR5x5 660-950 nm	QDC	76.3%/ 53.7%	87.4%/ 67.3%
	RF	78.3%/ 47.0%	89.6%/73.8%

8 target materials: quartz, barite (its main confounder), rutile, coal, feldspar, hematite, phlogopite and smectite

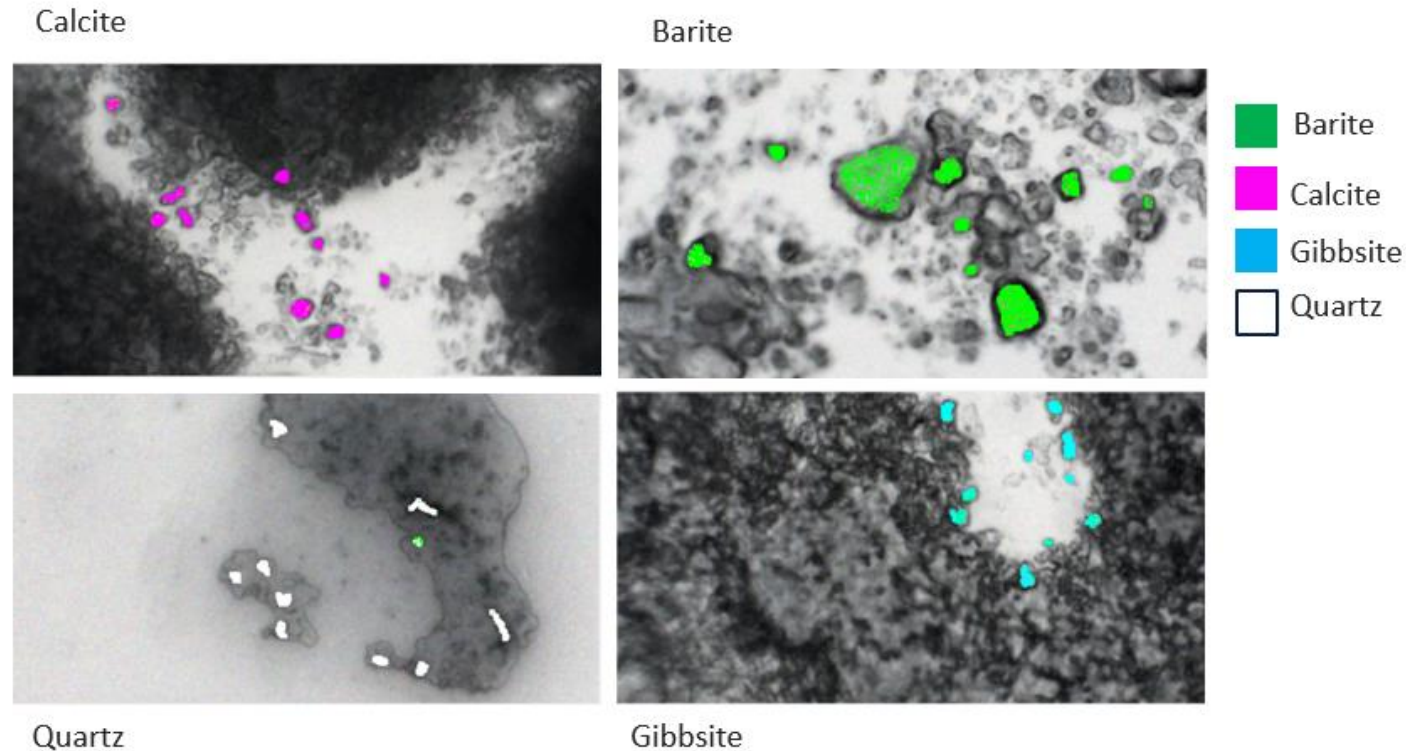

NIR 5x5
(670-950 nm)
40X



Towards higher portability: Snapshot cameras

BAND RELEVANCE ANALYSIS

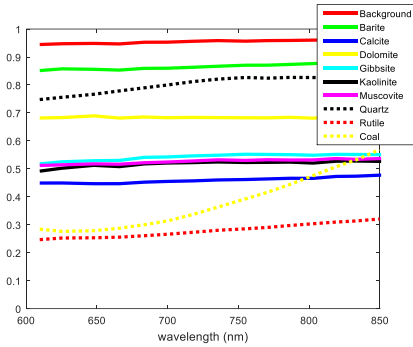

Genetic Algorithm



# of Bands	Bands (nm)	Mean Min
Best 5 NIR	685-847-894-907-945 nm	83.9% 65.7%
Best 4 NIR	685-847-916-945 nm	82.5% 64.8%
Best 3 NIR	667-847-907 nm	78.5% 53.3%
Best 5 RNIR	609-647-717-770 833 nm	76.3% 45.7%
Best 4 RNIR	647-699-735-833 nm	75.4% 30.5%
Best 3 RNIR	647-717-849 nm	74.8% 26.8%

# of Bands	Bands (nm)
Best 5 VNIR (460-900)	484.4-562.2-640.2-850.9-885.5 nm
Best 3 High Res VNIR (460-900)	643-718-871 nm

Similar bands selected as optimal

Pixel Classification accuracy (%) for different particle materials. Subset of 8 target materials.

Towards higher portability in exposure assessment

Leica Transmission microscope

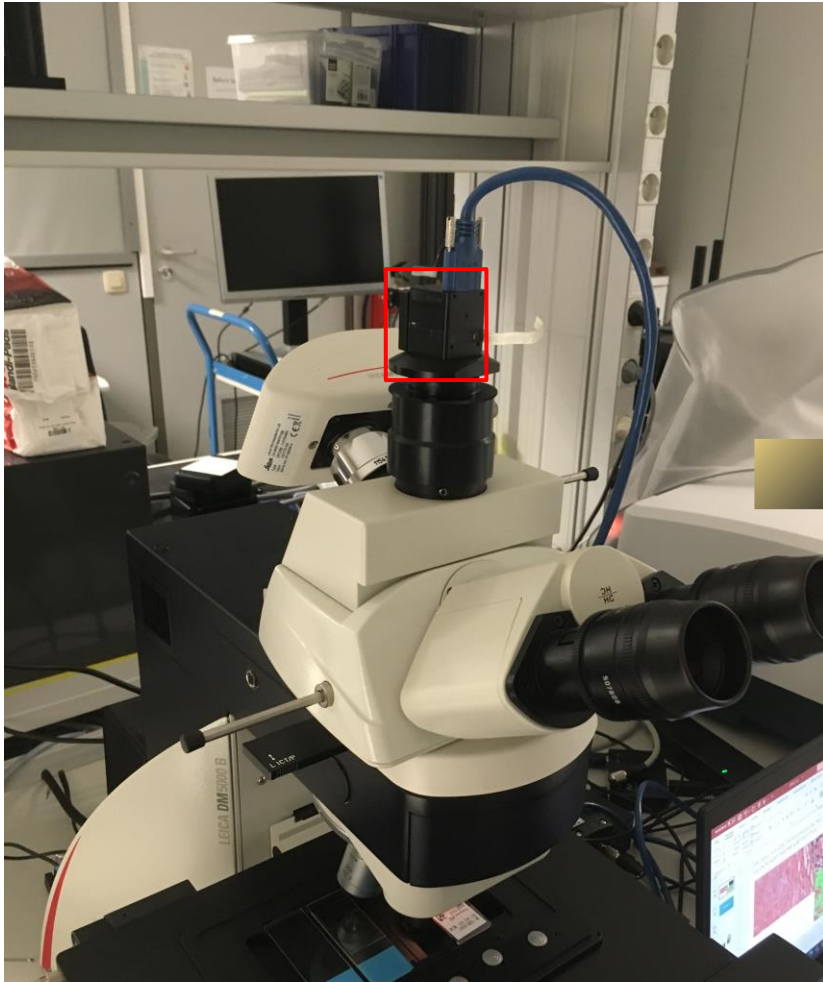

Inspection of particles on glass slide with spectral camera



Portable transmission microscope

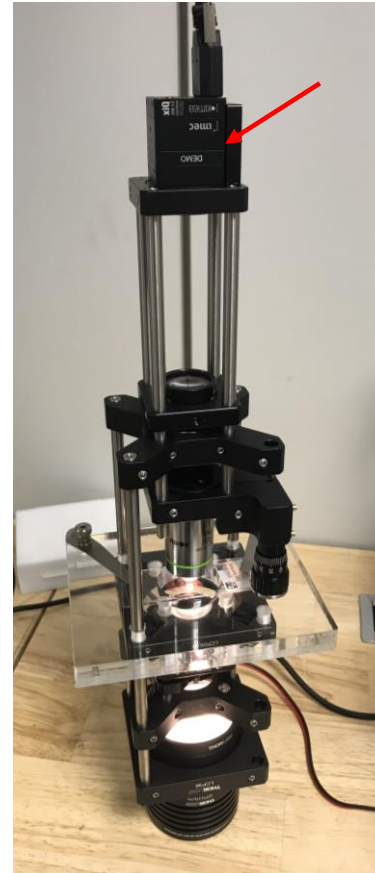

Current portable microscope

20X objective & halogen light covering VNIR range (400-1000 nm)

Used with multispectral snapshot cameras RedNIR (16 bands in 600-850 nm) and NIR (25 bands in 660-950nm)



Portable Microscope

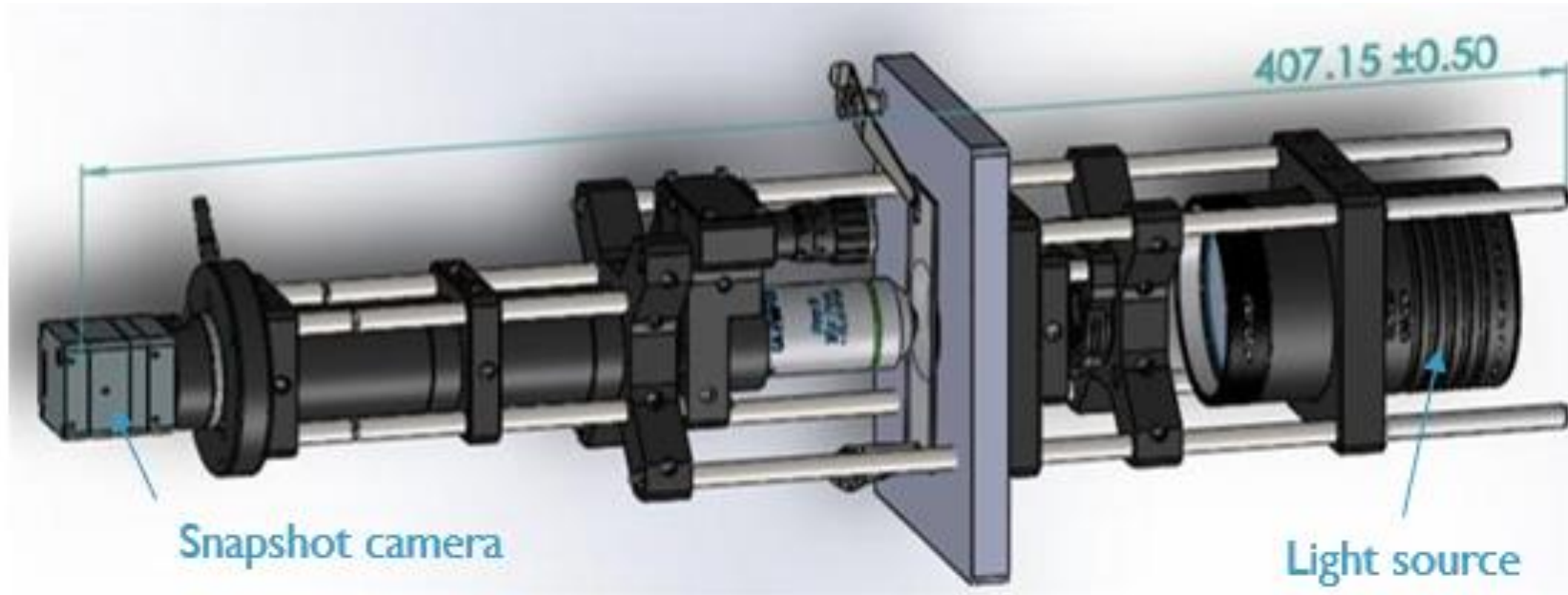

Current portable microscope
cost ~ 3k

Barite particles image

Multispectral Snapshot camera

2 Mpixel sensor
25 bands in 660-960 nm range
OR
16 bands in 600-850 nm range

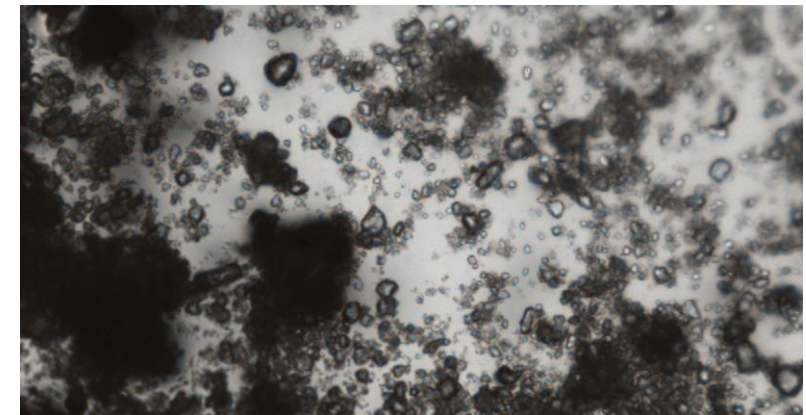
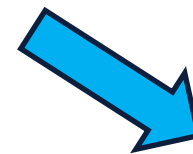

Discrimination of 12 materials is feasible

NIR 5X5 & PORTABLE TRANSMISSION MICROSCOPE WITH 20X

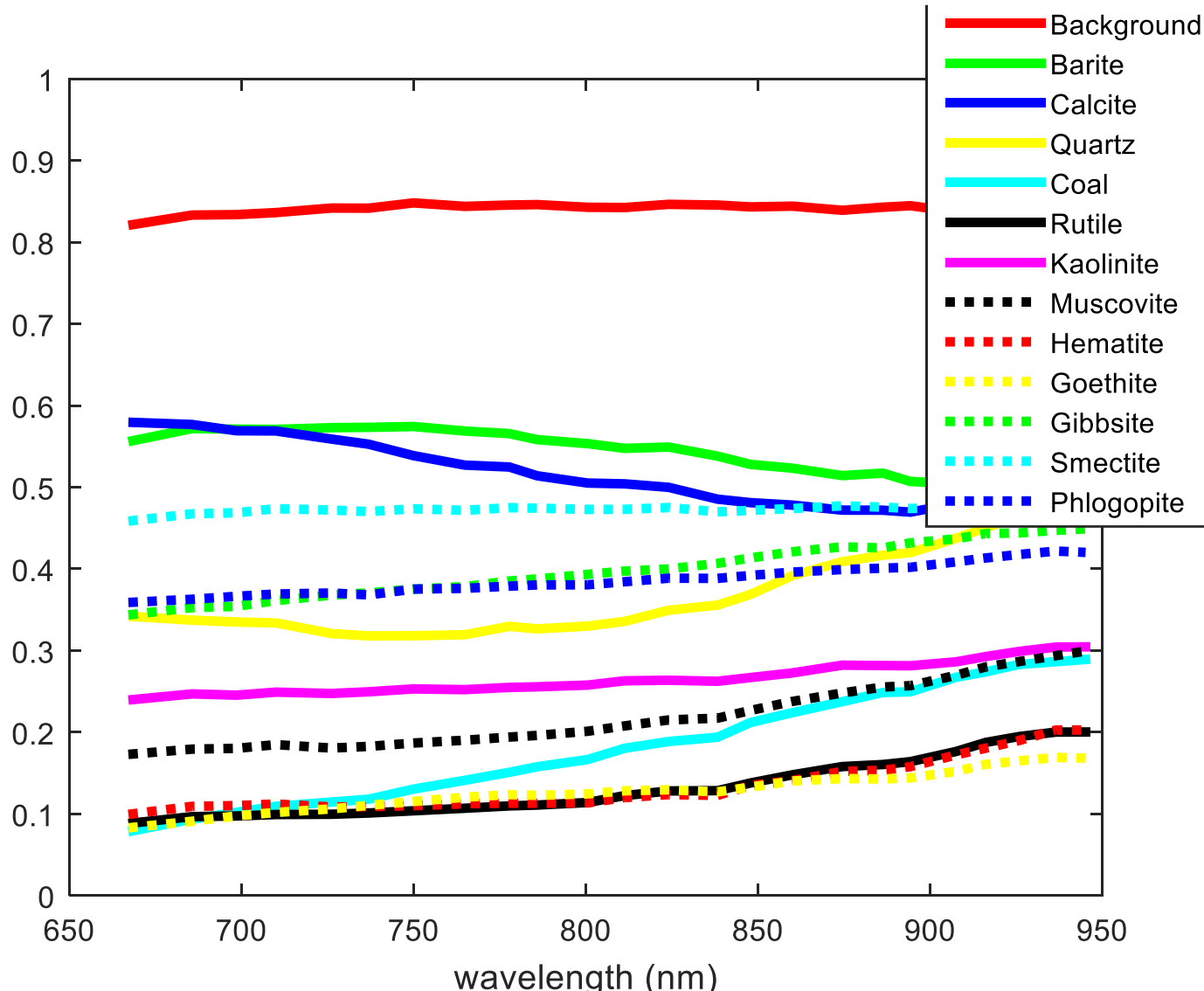

LDA+RF classifier



Mean pixel classification accuracy = 81.2%
Min pixel accuracy (Calcite) = 68.1%

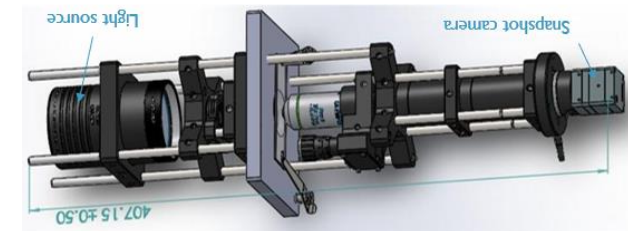

Multishot (spectral video acquisition with 31 bands)

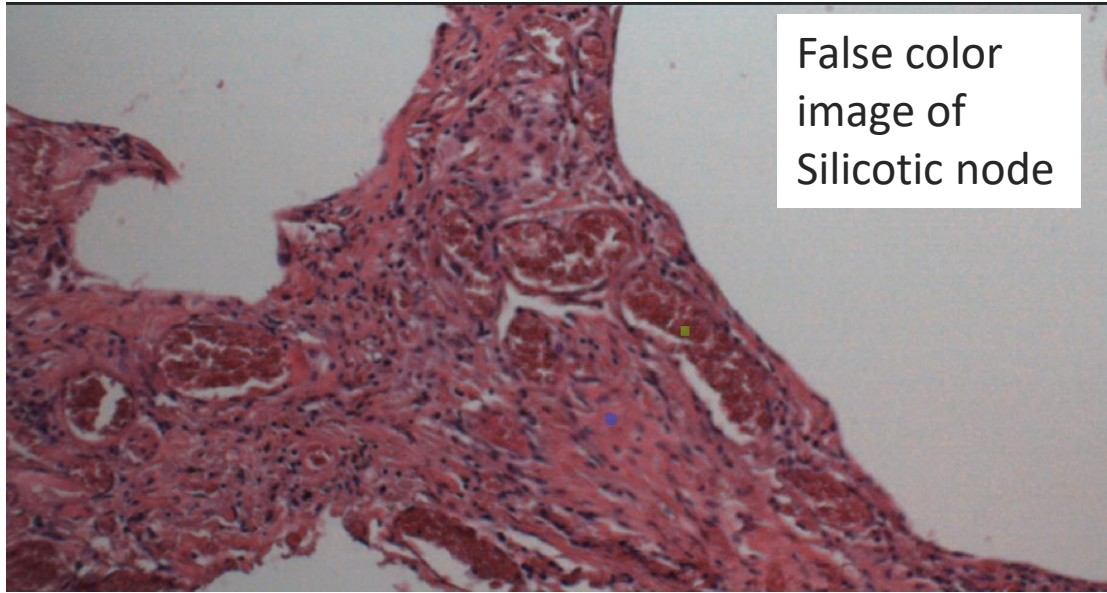

31 bands covering 460-900 nm range
@video rate acquisition speed

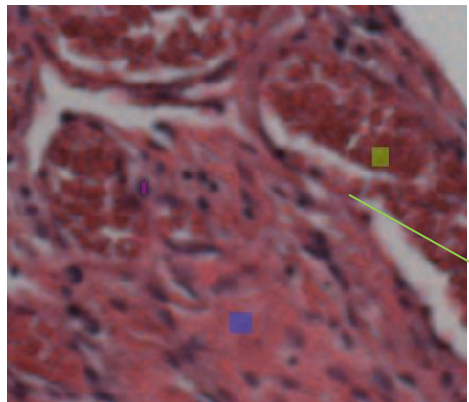
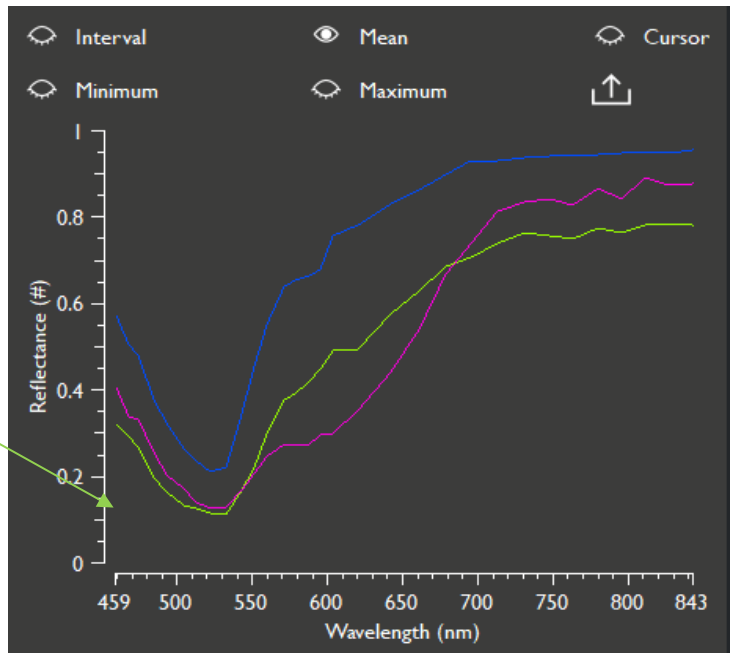
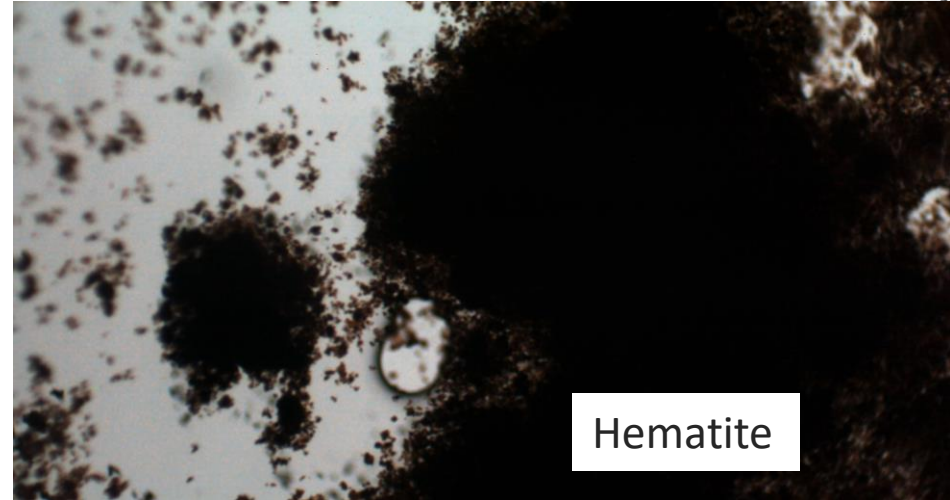

Next steps

- Further adaptations of microscope are required (positioning of stage, 40X objective)
- Continue validation of portable microscope with multispectral/hyperspectral cameras

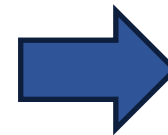
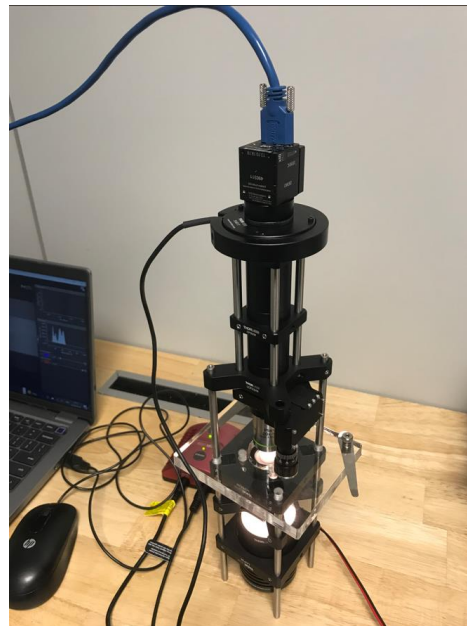
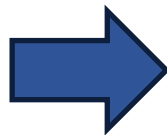
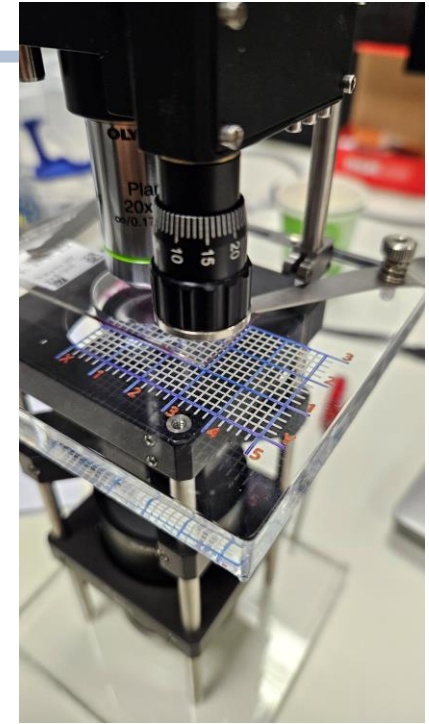

Output classification

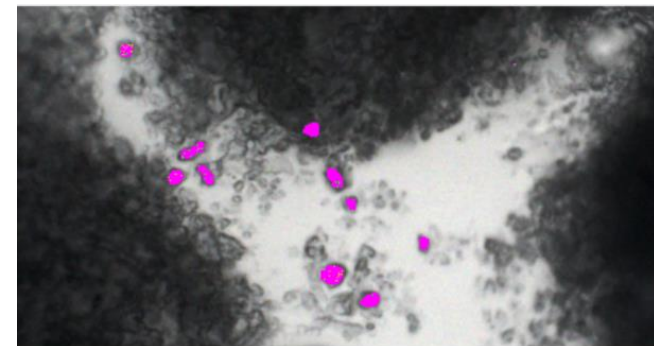

Conclusions

- Multispectral imaging microscopy enables particle material discrimination while offering:
 - Good spectral resolution at video rate
 - Higher portability for on-site measurement
 - More cost-efficient than traditional methods

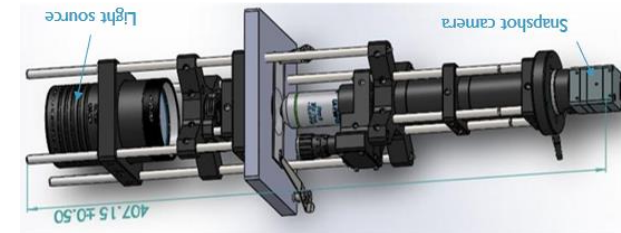

*You can see the cameras at
imec booth #1*





embracing a better life